

beml

BL10C

- BL10C is used for loading conveyors and mine cars in underground mines with cross headings, galleries and tunnels with a gradient of $\pm 14^\circ$.
- Modular design for ease of maintenance; contour styling of equipment.
- Rugged 1 Cum. capacity Bucket with hydraulically driven bi-directional chain conveyor system and side doors for controlled discharge on either side.
- Effective hydraulic system with high capacity cooler ensures maximum power utilisation with optimum performance and reliability for continuous operation.
- Hydrostatically driven track drive with automatic braking system ensure easy maneuverability and improved control.
- Flame proof, 3 phase Induction motor operating at 525 V is the primemover meeting all safety regulations for underground mining application.
- Flame proof electrical control system, hydraulic hoses and fire resistant hydraulic oil conform to safety regulations for underground mining application.
- Maintenance free, long life under carriage components with life time lubricated track & guide rollers and hydraulically adjustable idler assembly.
- Aesthetically designed operator seat with adjustable FOP canopy for enhanced operator comfort and safety.
- Lever operated controls with positive locking system for operating comfort and safety.

Operating weight : 8,600 kg	Bucket capacity : 1 Cu.m (SAE Rated)	Rated Power : 55 kW
-----------------------------	---	---------------------





SIDE DISCHARGE LOADER

SPECIFICATIONS

 ELECTRICAL SYSTEM	
FLP Induction Motor	
Make	Kirloskar Electric
Rated power	55 kW
Rated voltage	525 V \pm 10% 3 Phase, 50 Hz \pm 5%
Rated speed	1485 rpm
Design & testing conform to IS:325 - 1981, Flame proof, conforming to IS:2148 - 1981 & DGMS approved.	

 LIGHTING TRANSFORMER	
Flame proof conform to IS 2148 - 1981 & DGMS approved. Earth leakage circuit breaker. Hour meter. Door interlock to protect flashing hazards.	

 CABLES	
Trailing power cable is of elastomeric insulated mining type FT-7. Lighting & Control cable is of type PLC4. The above cables conform to IS:14494 - 1998. Flame proof, conforming to IS 2148 - 1981 & DGMS approved.	

 SIGNALING SYSTEM	
Head Lamps	24 V AC
Audio-Visual Alarm	12 V DC

 FIRE EXTINGUISHER	
Media	Dry Chemical Powder
Class of fire	B & C
Capacity	2 x 2 kg
Effective jet length	2 ~ 2.5 m
Duration of discharge	8 ~ 10 sec
Working pressure	12.5 bar
Gas cartridge contents	50 gms
Charged weight	4.6 Kg

 OTHER FEATURES	
Audio - visual alarm. Hydraulic oil low level cut OFF switch. Hydraulic oil high temperature cut OFF switch. Push button station is provided with lock & key arrangement. Foot pedal (Dead man) switch. (The above items are Flame proof, conforming to IS 2148 - 1981 & DGMS approved.)	

 SAFETY FEATURES	
Single phase preventer to protect burn out of motor. Forward & Reverse selection of prime mover. Over - current protection can be set on the field. Instantaneous short circuit protection manual resetting type. Shock protection: 80 - 200 / 300 mA earth leakage trip. Under voltage protection to save burn out of motor. Pilot core protection. Earth core protection. Isolator door is interlocked with the switches, hence can not be opened or closed unless switch is OFF. The contactor will open first in case of accidental pulling out of the trailing cable plug at either end when the motor is ON, preventing sparking. Ammeter is provided to monitor load fluctuations. Voltmeter is provided to monitor 3-phase voltage. Local start / stop in addition to operator start / stop.	

SPECIFICATIONS

 HYDRAULIC SYSTEM		
Hydraulic Pump		
Type	Gear, Triple pump	
Capacity	100+100+45 lpm	
Hydraulic Motors		
Travel drive	Axial piston motors with built-in counter balance valves and planetary reduction gear box	
Fan drive	Gear motor	
Bucket chain drive	Bi-directional Gerotor motor	
Control Valves.		
Type	Manually operated individual spool valve	
Relief valve settings (kg/cm ²)	Work attachment	140
	Travel circuit	140
Hydraulic Cylinders		
Heavy duty Double acting piston type		

 SERVICE REFILL CAPACITY	
Track Drive	2.5 x 2 ltr.
Hydraulic system	300 ltr.

 UNDER CARRIAGE	
Track frame	Sturdy, Stress absorbing and modular structure
Track shoe width	330 mm
No. of shoes on each side	31
No. of carrier roller on each side	1
No. of track rollers on each side	3
Grouser height	22 mm
Ground pressure	0.9 Kg/cm ²
Gradient	±14°

 FINAL DRIVE	
Drive type	Hydrostatic with axial piston motor and planetary reduction gear box for each track.
Travel and Steering	Forward / reverse travel and steering actuated with hand levers. Dual speed option. Independent drive to each track enables machine to make a pivot turn in either direction.
Travel Speed	Low : 0.53 m/sec (Min) High : 0.83 m/sec (Max)
Counter balance valve	Counterbalance valve fitted on each hydraulic motor acts as hydraulic brake. This also prevents possible overspeeding in down gradient.
Brakes	Wet disc type, spring applied hydraulically released brakes. The brakes are automatically released when levers are operated for travel.

 BUCKET	
Type	Bi-directional scraper conveyor side discharge
Capacity	1 Cum
Width (Side door closed)	1800 mm
Width (Side door opened)	2370 mm

 OVERALL DIMENSIONS	
Overall length	4830 mm
Overall width	1800 mm
Overall height	1900 ~ 2100 mm
Ground clearance	211 mm
Track gauge	1155 mm
Length of track on ground	1500 mm
Minimum discharge height	266 mm
Maximum discharge height	1807 mm
Minimum turning radius (Bucket at min. discharge position, outside corner of bucket)	2400 mm



WORKING RANGE AND DIMENSIONS

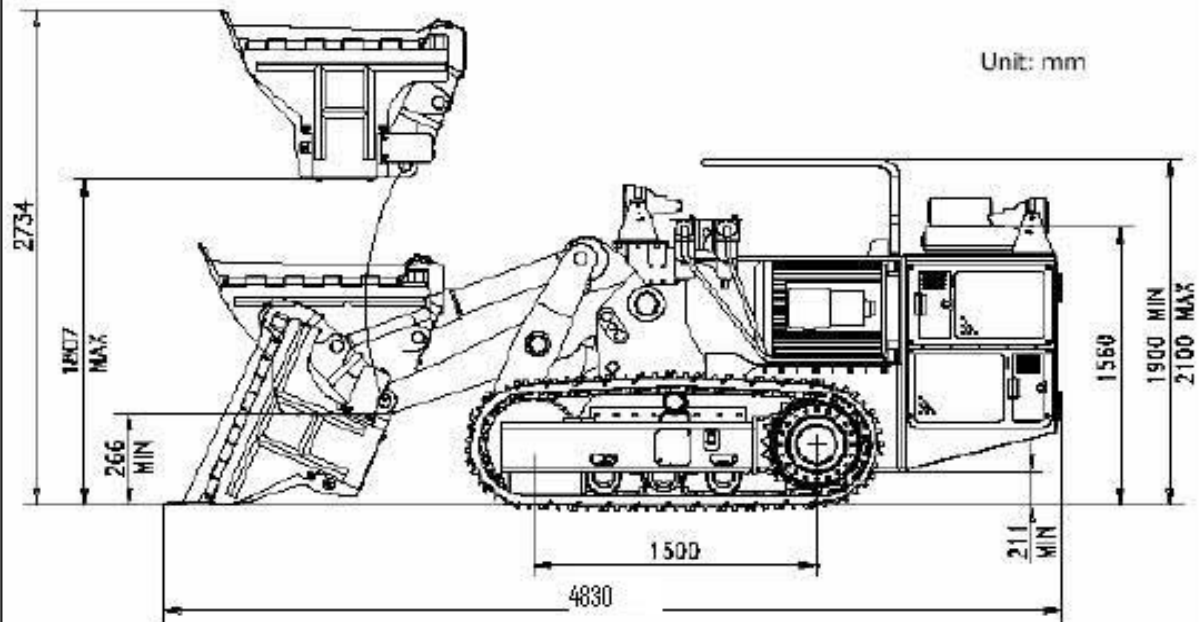

OPTIONAL ITEMS

Trailing cable.

Gate end box.

Materials and specifications are subject to change without notice. Illustrations may include optional equipment and accessories and may not include all standard equipment. All the specifications meet relevant ISO standards.



भारत अर्थमूवर्स लिमिटेड
BHARAT
EARTH MOVERS
LIMITED

MARKETING DIVISION

Beml Soudha, 23/1, 4th Main, S.R. Nagar, Bangalore - 560 027.
Ph : 91-080-22224141 (12 lines), Fax : 91-080-2226883/22224451
email : office@dm.beml.co.in

INTERNATIONAL DIVISION

V Floor, Unity Buildings, J.C. Road, Bangalore - 560 002,
Tel: 060-22233350, Fax: 060-22224874 email : office@exp.beml.co.in

REGIONAL OFFICES

BILASPUR : 1A, Indl Area, Sirgiti Sector-C, Bilaspur (CG)-405223
Ph : 07752-252052, Fax : 07752-252055,
email : bilaspur@rm.beml.co.in

CHENNAI : Flat No. 10-12 Supriya Estates, Sterling Road,
Nungambakkam, Chennai - 600 034
Ph: 044-26257319, Fax: 044-26257319, email: chennai@rm.beml.co.in

HYDERABAD : 3-6-114, Himayat Nagar, Hyderabad-500-020
Ph : 040-23227032, Fax : 040-23221794
email : bemlhyd@hd2.dct.net.in

KOLKATA : Flat No.6,10&11, 5A, Lord Sinha Road, Kolkata 700071
Ph : 033-22825803, Fax : 033-22821033
email : kolkata@rm.beml.co.in

MUMBAI : Rajmahal, 84, Veer Nariman Road, Churchgate,
Mumbai-400020, Ph : 022-22852017, Fax : 022-22852633
email : mumbai@rm.beml.co.in

NAGPUR : 33, Coment Road, Shivajinagar, Nagpur-440 010
Ph : 0712-2248435, Fax : 0712-2248343
email : bemlnag.ngp@sancharnet.in

NEW DELHI : Flat E,F,G,H Vandana, 11th Floor, Tolstoy Marg, New
Delhi-110 001, Ph: 011-23316500, Fax: 011-23315085
email: delhi@rm.beml.co.in

RANCHI : 712C, Circular Road, Ranchi-834 001
Ph : 0651-2560370, Fax : 0651-2560197 email : ranchi@rm.beml.co.in

SAMBALPUR : BEML Complex, NH-6, Barapalli, Sambalpur-768 150
Ph : 0663-2521604, Fax : 0663-2521603,
email : sambalpur@rm.beml.co.in

SINGRAULI : PB No.5, Jhingurdeh Colliery Sidhi, Singrauli-486 669
Ph : 07805-266668, Fax : 07805-267282,
email : singrauli@rm.beml.co.in

DISTRICT OFFICES

Ahmedabad, Asansol, Bhaia, Bhubaneswar, Chandrapur, Dhanbad, Guwahati, Hubli,
Jammu, Kohagudem, Madurai, Noyyoli, Panaji, Ramagundam, Udaipur

Form No.BL10C/01/001/02/2005

बी ई एम एल लिमिटेड BEML LIMITED

A Govt. of India Miniratna Company Under Ministry of Defence

Business Network

Corporate Office

BEML Soudha, 23/1, 4th Main,
S.R. Nagar, Bangalore-560 027

T + 91 80 22963240, 22963250

F + 91 80 22963278/516/280/164

E-mail: office@cpd.beml.co.in
office@pr.beml.co.in

International Business Division

BEML Soudha, 23/1, 4th Main,
S.R. Nagar, Bangalore-560 027

T + 91 80 22222730, 22233350
22963187, 22963215

F + 91 80 22224874

E-mail: office@export.beml.co.in

Marketing Division

5th Floor, Unity Building,
J.C. Road, Bangalore-560 002

T + 91 80 22963501/02/07/510/553

F + 91 80 22963541

E-mail: m@beml.co.in
bemldealer@dealer.beml.co.in

Global Service HQ

C-6, Central Hingna Road,
MIDC Industrial Area, Hingna,
Nagpur-440 028

T + 91 7104 287097/287098

F + 91 7104 287099

E-mail: ss.servicehq@gmail.com
ss@servicehq.beml.co.in

REGIONAL OFFICES

Bangalore

No -23/1, Haudin Road Cross,
Ulsoor Road, Bangalore - 560008
Karnataka

T + 91 080 22963590/92/93/94
F + 91 080 2558156
E-mail: mg@beml.co.in

Bilaspur

1/A, Sector-C, Srigitti Industrial Area,
P.O: Tifra, Bilaspur - 495 223.
Chhattisgarh.

T + 91 7752 252745, 252598
F + 91 7752 252065
E-mail: bilaspur@rm.beml.co.in

Chennai

Flat No. 10&11, Supriya Estates,
Sterling Road, Nungambakkam,
Chennai - 600 034, Tamil Nadu

T + 91 44 28276576 / 22820844
F + 91 44 28257319
E-mail: chennai@rm.beml.co.in

Dhanbad

Kamal Kunj, Kola Kusuma,
Saraidhela, Dhanbad - 828 127
Jharkhand

T + 91 326 2200180 / 2208982/5827
F + 91 326 2200182
E-mail: dhanbad@rm.beml.co.in

Hyderabad

3-6-114, Himayat Nagar,
Hyderabad - 500 029
Andhra Pradesh

T + 91 40 23225250 / 7032 / 2166
F + 91 40 23221794
E-mail: hyderabad@rm.beml.co.in

Kolkata

35/1, Taratala Road,
Kolkata - 700 088.
West Bengal

T + 91 33 24015286 / 87 / 98 / 99
F + 91 33 24015288
E-mail: kolkata@rm.beml.co.in

Mumbai

C/o Richardson & Cruddas (1972) Ltd.
3rd Floor, Corporate Office Building
Sir J.J Road Byculla, Mumbai - 400 020

T + 91 22 23781457 / 23781382
F + 91 22 23780915
E-mail: mumbai@rm.beml.co.in

Nagpur

33, Cement Road,
Shivaji Nagar,
Nagpur - 440 010, Maharashtra.

T + 91 0712 2248435 / 2248343
F + 91 0712 2249997
E-mail: nagpur@rm.beml.co.in

New Delhi

Flat EFGH, 'Vandana', 11th Floor,
Tolstoy Marg,
New Delhi - 110 001

T + 91 11 23310035 / 23316500
F + 91 11 23325085
E-mail: delhi@rm.beml.co.in

Ranchi

206/D-1, Bhagirathi, (Behind NCC Campus),
Rameshwaram Colony, Bariatu Road,
Ranchi, Jharkhand - 834009

T + 91 651 2540710 / 2540791
F + 91 651 2540624
E-mail: ranchi@rm.beml.co.in

Sambalpur

BEML Complex, NH-6, Baraipalli,
Sambalpur - 768 150
Orissa.

T + 91 663 2521604 / 2520393
F + 91 663 2521603
E-mail: sambalpur@rm.beml.co.in

Singrauli

PB No. 5, Jhingurdha Colliery,
Sidhi, Singrauli - 486 889
Madhya Pradesh.

T + 91 7805 268260 / 266668
F + 91 7805 267282 / 318
E-mail: singrauli@rm.beml.co.in

DISTRICT OFFICES

Ahmedabad

266-1, Dilbaug Villa,
Darshan Society Road, Navrangpura,
Ahmedabad - 380 009. Gujarat

T + 91 79 26445523
F + 91 79 26423950
E-mail: ahmedabad@rm.beml.co.in

Asansol

3, Bumpur Road,
Asansol - 713 304
West Bengal

T + 91 341 2252480
F + 91 341 2250601
E-mail: asansol@rm.beml.co.in

Bacheli

Behind Central Stores
of NMDC Ltd., Depot 5, Bacheli - 494 553.
Chhattisgarh

T + 91 7857 200518
F + 91 7857 230005
E-mail: bacheli@rm.beml.co.in

Bhopal

Ground Floor, Hall No.1, Chittod Complex
Zone-1, Maharana Pratap Nagar (MP Nagar)
Bhopal - 462 023

T + 91 755 2550711
E-mail: bemlbhopal@gmail.com

DISTRICT OFFICES

Bhubaneswar

252/A, LEWIS Road,
Bhubaneswar - 751 014
Orissa

T + 91 674 2434428
T/F + 91 674 2434427
E-mail: bhuvaneshwar@rm.beml.co.in

Chandrapur

Mamidwar, Tiles Factory Compound,
Ghugus Road, Padoli,
Chandrapur - 442 406 Maharashtra

T + 91 7172 287230
F + 91 7172 287072
E-mail: chandrapur@rm.beml.co.in

Cochin

No. 55/845, Chittor Road, Ernakulam South
Cochin-682 016

T + 91 484 2375138
E-mail: bemlkochi@gmail.com

GOA

67-12, Dattaprasad Building, 3rd Floor, MG road
Timphoni School, Panjim, - 403001, Goa

T + 91 832 2225135
E-mail: goa@rm.beml.co.in

Guwahati

Hegrabari Road, House No. 11,
Ganesh Puri, Dispur,
Guwahati - 781 006 Assam

T + 91 361 2232966
F + 91 361 2232967
E-mail: guwahati@rm.beml.co.in

Hospet

No. 1431, Manjunatha Complex, New Ward No. 31,
Bhagat Singh Nagar, Opp. KSSIDC Indl. Estate,
Dam Road, Hospet - 583 203, Karnataka

T + 91 8394 230173
F + 91 8394 230172
E-mail: hospet@rm.beml.co.in

Jammu

62C, Block D/C, Gandhi Nagar,
Jammu tawi - 180 004
Jammu and Kashmir

T + 91 191 2430447
F + 91 191 2477469
E-mail: jammu@rm.beml.co.in

Kothagudem

Old Project Planning Department,
Near SCCL Corporate Office,
Kothagudem - 507 101, Andhra Pradesh

T + 91 8744 245572
F + 91 8744 245530
E-mail: kothagudem@rm.beml.co.in

LEH

#135, Fort Road, Sheynam
LEH, Ladakh, 194 101

T + 91 9622973460
E-mail: bemlleh@gmail.com

Madurai

9-4/49, Kalai Nagar, IInd Main Road,
Madurai - 625 017, Tamil Nadu.

T/F + 91 452 2649458
E-mail: madurai@rm.beml.co.in

Neyveli

F-4, Rajendraprasad Road, Block-27
Neyveli - 607 803, Tamil Nadu

T/F + 91 4142 268517
E-mail: neyveli@rm.beml.co.in

Panjim

67-12, Dattaprasad Building, III Floor, MG Road,
Timphoni School, Panjim - 403 001, Goa

T/F + 91 832 2225135
E-mail: goa@rm.beml.co.in

Ramagundam

Opp. SCCL 11A Mines, Manthani,
(PO) Jallaram, GK - 505 184
Karimnagar Dt. Andhra Pradesh

T + 91 8728 248299
F + 91 8728 247423
E-mail: ramagundam@rm.beml.co.in

Udaipur

20-B Uchhaba Bhawan, Bedia Road,
New Fatehpura, Udaipur - 313 001.
Rajasthan

T + 91 294 2452053, 2452055
F + 91 294 2452054
E-mail: udaipur@rm.beml.co.in

Vijayawada

District Manager : Mr Rambabu

Mob +91 8330930990

Visakhapatnam

No. 8-45-11, 4h Lane, China Waltair Colony,
Visakhapatnam - 530 003

T/F 0891 2754608
E-mail: vizag@rm.beml.co.in

www.bemlindia.com

Represented by :

बी ई एम एल लिमिटेड BEML LIMITED

A Govt. of India Miniratna Company Under Ministry of Defence