

BWS70

WATER SPRINKLER

- Top Performance
- Enhanced Productivity
- Increased Reliability
- Excellent Serviceability
- Exceptional Manoeuvrability
- Superior Operating Comfort
- Improved Safety



Flywheel power (net) : 674 kW (904HP) @ 2100 rpm

Capacity : 70,000 Litres

BWS70

WATER SPRINKLER

Salient Features :

Top Performance :

High power engine & well matched with mechanical type transmission offers ample reserve power, high hp to weight ratio. Pressurised discharged through sprinkling nozzles & higher spreading width for effective dust settling is assisted by hyd. Motor & centrifugal pump.

Enhanced Productivity :

High power to weight ratio gives ample reserve power for faster cycle time. Larger tank capacity ensures high productivity.

Increased Reliability :

Oil cooled multiple disc rear breaks are free from fading even during repeated & continuous operations. Due to the ample capacity the rear breaks also act as retarder break.

Excellent Serviceability :

Low maintainability and repairability index, make easy servicing & increases availability.

Exceptional Manoeuvrability :

Orbitrol full time Power steering with a good combination of steering angle, shorter turning radius, wheel tread and wheel base provide high degree of manoeuvrability.

Superior Operating Comfort :

Human-engineered cabin with ergonomically designed operator's compartment & controls offer maximum comfort and operational ease. Pneumatically operated water valves reduces operators effort.

Improved Safety :

Features include Integral ROPS cabin, emergency steering, dual braking system to meet relevant safety standards.



ENGINE

Make	Cummins(India)
Model:	QST30-C
Type	IC-Diesel, 4stroke, turbo charged, after cooled, direct injection, water cooled, meets EPA Tier 1 emission norms
Number of cylinders	12, inline
Bore & Stroke (mm)	∅ 140 x 165 mm
Displacement	30.47 l
Fly wheel power	674 kW (904 HP)@ 2100 rpm
Maximum net torque	4108 N-m @ 1300rpm Meets SAE J 1349
Electricals	
Starting motor	24V DC, 9 kW (2 nos)
Battery	4 x 12V, 200 Ah
Alternator	24 V, 75 A

POWER TRAIN

Transmission					
Model	BEML				
Type	Power shift with automatic Lock up clutch				
Drive axle	Full floating				
Differential					
Type	Traction sensing, automatic				
Ratio	3.07 : 1				
Final Drive					
Type	Planetary reduction type				
Ratio	7.94 : 1				
Total reduction	24.37: 1				
Travel speeds (km/h)					
Range	1st	2nd	3rd	4th	5th
Forward	8.6	12.1	16.3	21.9	29.5
Reverse			10.2		

HYDRAULIC SYSTEM

Hydraulic pump	
Type	Two no. tandem gear pump for hoist, steering and brake oil cooling
Capacity	Steering & Hoist(Hyd motor) : 478 l/min @ 2100 rpm BoC : 478 l/min @ 2100 rpm
Relief pressure	
Motor	14.7 Mpa(hydraulic motor);
Hydraulic Motor	
Type	Vane Type
Power (Max.)	60 kW (80 hp) @ 14.7 MPa (150 kg/cm ²)
Speed	2900 rpm @ 245 l/min
Control Valve	Spool type

TANK

Construction	
All welded reinforced, 12 mm thick steel Plates, at the base 10 mm plate at the sides and 8mm on top, Cross baffles to avoid heavy surging.	
Interior Coating.	
Coated with special anti-corrosive paint	

STANDARD EQUIPMENT

GENERAL : Rear View mirror (left & right), head lights, tail lamp, back up light, roof lamp, wind shield, wiper, tilttable steering, rock ejectors, cabin floor mat, emergency brake, emergency steering, sun visor, asst. operator seat, tool kit, under view mirror, engine over speed protection, vandalism protection system, (radiator, fuel tank, hyd.tank), front & rear turn signal lamp, (left & right) ,portable fire extinguisher, ROPS cabin, front brake cut-off switch, auto fire suppression system.

INDICATORS/GAUGES : Hi-beam, reverse, turn signal, lube oil pressure, water temperature, parking brake and emergency steering "ON", alternator warning, transmission oil temperature and pressure, fuel level, transmission filter clogging, air pressure and convertor oil temperature, electronic water level indicator for water tank.

ALARMS : Air pressure, water temperature, transmission oil temperature & pressure, lube oil pressure, convertor oil temperature, transmission filter clogging and parking brake "ON", Low fuel level.

Guards: Cab guard, cab step & safety guard cat walk, engine & trans. belly guard, drive shaft guard (front & rear).

OPTIONAL ACCESSORIES

Tyre inflation kit, suspension charging kit, air conditioner and heater unit, fast fill system for fuel, parking brake interlock, radial tyres, front pressurised sprinkling, full fledged fire fighting through monitor, mist system, ABS/ASR, Injector bank monitoring system, auto dipping system, rear view camera , radio FM/AM, electronic type proximity avoidance system. wet multiple disc brake, SAHR wet multiple disc integral parking brake

SUSPENSION

Type-front	Wheel mounted, hydropneumatic integral rebound control	
Rear	Axle mounted, inverted hydropneumatic, Integral rebound control	
Cylinder	Front	Rear
Quantity	2 nos	2 nos
Bore x Stroke	∅ 250 x 376 mm	∅ 250 x 190 mm
Charging pressure	2.8 MPa (31.7 kg/cm ²)	1.9 MPa (20.4kg/cm ²)
Load/deflection Rate		
Empty	952 kg/cm ²	712 kg/cm ²
Loaded	3110 kg/cm ²	15373 kg/cm ²

STEERING SYSTEM

Type	Orbitrol, full time power steering
Cylinder	
Type	Double acting, piston type
Quantity	Two
Bore x Stroke	∅ 110 x 430mm
Relief pressure	20.6 MPa (210 kg/cm ²)
Emergency Steering	Electrically driven hydraulic Pump and motor
Performance	
Turning radius	10.7 m
Vehicle clearance Dia	23 m

BRAKES

Service Brakes	
Front	Air-over-hydraulic, dry caliper disc
Rear	Air-over-hydraulic, wet multiple disc
Emergency	Air-over-hydraulic, automatic application through relay emergency valves
Parking brake	Spring actuated dry caliper disc drive shaft
Retarder brakes	Rear brake serves as retarder brake Meets ISO 3450 performance requirements

TYRES

Size	24.00 x 49, 48PR (E-4) tubeless - standard
(Front & Rear)	
Rim size	17.00 x 49
BEML recommends the user to evaluate all job conditions and consult the tyre, manufacturer to make proper tyre selection.	

SYSTEM REFILL CAPACITIES

Systems	Capacity (l)
Cooling system	270
Fuel tank	1240
Engine lub. oil	60
Transmission	110
Differential	40
Final drive (each side)	180
Hydraulic tank	490
Air tanks	175
Suspension	- Front 24 (each) - Rear 16 (each)
Water tank	70,000

GUARDS

Engine & Transmission belly guard, cab spill guard, drive line protector, radiator fan guard and hand rails (Meets ISO 3457 requirements)

DIMENSIONS(in mm)

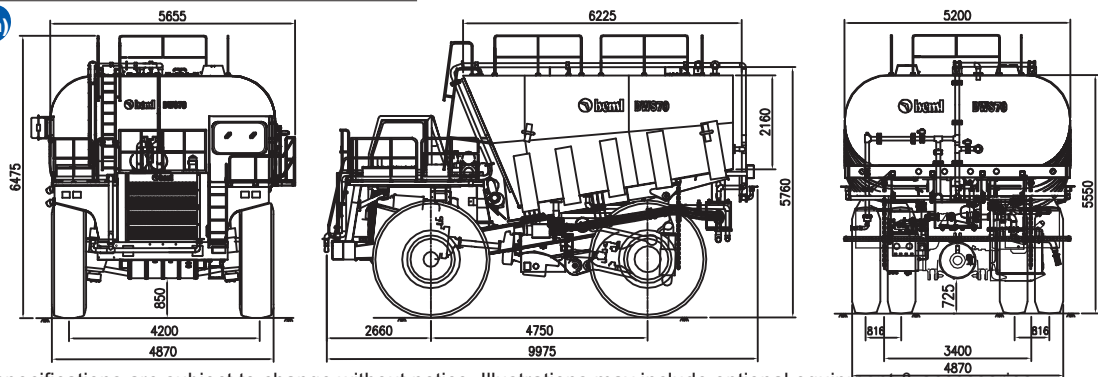

Material and specifications are subject to change without notice, Illustrations may include optional equipment & accessories

CABIN

Type	Integral ROPS cabin with tinted safety glass and electronic display dash board
-------------	--

MASS

Net vehicle mass	64,000 kg	
Rated payload	70,000 kg	
Gross vehicle mass	1,34,000 kg	
Mass distribution	Empty	Loaded
Front axle, kg	28,800	42,210
Rear axle, kg	35,200	91,790

PERFORMANCE CHART

Engine : QST30C
Axle Ratio : 7.94 :1
Total Reduction Ratio : 24.37 :1

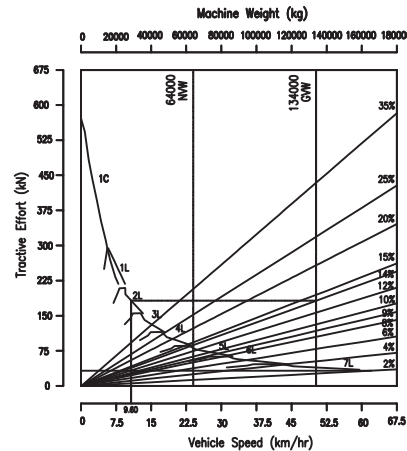

How to use this chart : Draw a straight line from gross vehicle mass to percent of total resistance (total resistance = grade resistance + rolling resistance) and extend the same line upto tractive effort. From this point draw horizontally to the curve with the highest obtainable gear, then vertically down to obtain maximum speed.

WATER SYSTEM

Water Pump	
Type	Centrifugal Pump
Capacity	180 m ³ /hr@2900 rpm & 85 m head
Drive	Hydraulic motor through flexible coupling
Piping	
Suction	100mm
Discharge	80mm
Valves	Butterfly type
Sprinkling	
Pressurised Sprinkling	Constant Sprinkling velocity Maintained by a Centrifugal pump
Spreading width	21 m
Gravity Sprinkling	Through perforated manifold connected to Tank Bottom
Nozzles	Fish tail type
Self filling	By connecting the pump suction to out side Reservoir or pond through armoured hose with foot valve unit
Fire fighting Unit	Quick connecting adaptor provided for fire fighting with canvas hose & triple purpose nozzle.
Mist system (Optional):	192 nos, Cluster nozzles, 300-400 Mic. Spray size & 1.5- 2m spray distance

बी ई एम एल लिमिटेड BEML LIMITED

A Govt. of India Miniratna Company Under Ministry of Defence

Business Network

Corporate Office

BEML Soudha, 23/1, 4th Main,
S.R. Nagar, Bangalore-560 027

T + 91 80 22963240, 22963250

F + 91 80 22963278/516/280/164

E-mail: office@cpd.beml.co.in
office@pr.beml.co.in

International Business Division

BEML Soudha, 23/1, 4th Main,
S.R. Nagar, Bangalore-560 027

T + 91 80 22222730, 22233350
22963187, 22963215

F + 91 80 22224874

E-mail: office@export.beml.co.in

Marketing Division

5th Floor, Unity Building,
J.C. Road, Bangalore-560 002

T + 91 80 22963501/02/07/510/553

F + 91 80 22963541

E-mail: m@beml.co.in
bemldealer@dealer.beml.co.in

Global Service HQ

C-6, Central Hingna Road,
MIDC Industrial Area, Hingna,
Nagpur-440 028

T + 91 7104 287097/287098

F + 91 7104 287099

E-mail: ss.servicehq@gmail.com
ss@servicehq.beml.co.in

REGIONAL OFFICES

Bangalore

No -23/1, Haudin Road Cross,
Ulsoor Road, Bangalore - 560008
Karnataka

T + 91 080 22963590/92/93/94
F + 91 080 2558156
E-mail: mg@beml.co.in

Bilaspur

1/A, Sector-C, Srigitti Industrial Area,
P.O: Tifra, Bilaspur - 495 223.
Chhattisgarh.

T + 91 7752 252745, 252598
F + 91 7752 252065
E-mail: bilaspur@rm.beml.co.in

Chennai

Flat No. 10&11, Supriya Estates,
Sterling Road, Nungambakkam,
Chennai - 600 034, Tamil Nadu

T + 91 44 28276576 / 22820844
F + 91 44 28257319
E-mail: chennai@rm.beml.co.in

Dhanbad

Kamal Kunj, Kola Kusuma,
Saraidhela, Dhanbad - 828 127
Jharkhand

T + 91 326 2200180 / 2208982/5827
F + 91 326 2200182
E-mail: dhanbad@rm.beml.co.in

Hyderabad

3-6-114, Himayat Nagar,
Hyderabad - 500 029
Andhra Pradesh

T + 91 40 23225250 / 7032 / 2166
F + 91 40 23221794
E-mail: hyderabad@rm.beml.co.in

Kolkata

35/1, Taratala Road,
Kolkata - 700 088.
West Bengal

T + 91 33 24015286 / 87 / 98 / 99
F + 91 33 24015288
E-mail: kolkata@rm.beml.co.in

Mumbai

C/o Richardson & Cruddas (1972) Ltd.
3rd Floor, Corporate Office Building
Sir J.J Road Byculla, Mumbai - 400 020

T + 91 22 23781457 / 23781382
F + 91 22 23780915
E-mail: mumbai@rm.beml.co.in

Nagpur

33, Cement Road,
Shivaji Nagar,
Nagpur - 440 010, Maharashtra.

T + 91 0712 2248435 / 2248343
F + 91 0712 2249997
E-mail: nagpur@rm.beml.co.in

New Delhi

Flat EFGH, 'Vandana', 11th Floor,
Tolstoy Marg,
New Delhi - 110 001

T + 91 11 23310035 / 23316500
F + 91 11 23325085
E-mail: delhi@rm.beml.co.in

Ranchi

206/D-1, Bhagirathi, (Behind NCC Campus),
Rameshwaram Colony, Bariatu Road,
Ranchi, Jharkhand - 834009

T + 91 651 2540710 / 2540791
F + 91 651 2540624
E-mail: ranchi@rm.beml.co.in

Sambalpur

BEML Complex, NH-6, Baraipalli,
Sambalpur - 768 150
Orissa.

T + 91 663 2521604 / 2520393
F + 91 663 2521603
E-mail: sambalpur@rm.beml.co.in

Singrauli

PB No. 5, Jhingurdha Colliery,
Sidhi, Singrauli - 486 889
Madhya Pradesh.

T + 91 7805 268260 / 266668
F + 91 7805 267282 / 318
E-mail: singrauli@rm.beml.co.in

DISTRICT OFFICES

Ahmedabad

266-1, Dilbaug Villa,
Darshan Society Road, Navrangpura,
Ahmedabad - 380 009. Gujarat

T + 91 79 26445523
F + 91 79 26423950
E-mail: ahmedabad@rm.beml.co.in

Asansol

3, Bumpur Road,
Asansol - 713 304
West Bengal

T + 91 341 2252480
F + 91 341 2250601
E-mail: asansol@rm.beml.co.in

Bacheli

Behind Central Stores
of NMDC Ltd., Depot 5, Bacheli - 494 553.
Chhattisgarh

T + 91 7857 200518
F + 91 7857 230005
E-mail: bacheli@rm.beml.co.in

Bhopal

Ground Floor, Hall No.1, Chittod Complex
Zone-1, Maharana Pratap Nagar (MP Nagar)
Bhopal - 462 023

T + 91 755 2550711
E-mail: bemlbhopal@gmail.com

DISTRICT OFFICES

Bhubaneswar

252/A, LEWIS Road,
Bhubaneswar - 751 014
Orissa

T + 91 674 2434428
T/F + 91 674 2434427
E-mail: bhuvaneshwar@rm.beml.co.in

Chandrapur

Mamidwar, Tiles Factory Compound,
Ghugus Road, Padoli,
Chandrapur - 442 406 Maharashtra

T + 91 7172 287230
F + 91 7172 287072
E-mail: chandrapur@rm.beml.co.in

Cochin

No. 55/845, Chittor Road, Ernakulam South
Cochin-682 016

T + 91 484 2375138
E-mail: bemlkochi@gmail.com

GOA

67-12, Dattaprasad Building, 3rd Floor, MG road
Timphoni School, Panjim, - 403001, Goa

T + 91 832 2225135
E-mail: goa@rm.beml.co.in

Guwahati

Hegrabari Road, House No. 11,
Ganesh Puri, Dispur,
Guwahati - 781 006 Assam

T + 91 361 2232966
F + 91 361 2232967
E-mail: guwahati@rm.beml.co.in

Hospet

No. 1431, Manjunatha Complex, New Ward No. 31,
Bhagat Singh Nagar, Opp. KSSIDC Indl. Estate,
Dam Road, Hospet - 583 203, Karnataka

T + 91 8394 230173
F + 91 8394 230172
E-mail: hospet@rm.beml.co.in

Jammu

62C, Block D/C, Gandhi Nagar,
Jammu tawi - 180 004
Jammu and Kashmir

T + 91 191 2430447
F + 91 191 2477469
E-mail: jammu@rm.beml.co.in

Kothagudem

Old Project Planning Department,
Near SCCL Corporate Office,
Kothagudem - 507 101, Andhra Pradesh

T + 91 8744 245572
F + 91 8744 245530
E-mail: kothagudem@rm.beml.co.in

LEH

#135, Fort Road, Sheynam
LEH, Ladakh, 194 101

T + 91 9622973460
E-mail: bemlleh@gmail.com

Madurai

9-4/49, Kalai Nagar, IInd Main Road,
Madurai - 625 017, Tamil Nadu.

T/F + 91 452 2649458
E-mail: madurai@rm.beml.co.in

Neyveli

F-4, Rajendraprasad Road, Block-27
Neyveli - 607 803, Tamil Nadu

T/F + 91 4142 268517
E-mail: neyveli@rm.beml.co.in

Panjim

67-12, Dattaprasad Building, III Floor, MG Road,
Timphoni School, Panjim - 403 001, Goa

T/F + 91 832 2225135
E-mail: goa@rm.beml.co.in

Ramagundam

Opp. SCCL 11A Mines, Manthani,
(PO) Jallaram, GK - 505 184
Karimnagar Dt. Andhra Pradesh

T + 91 8728 248299
F + 91 8728 247423
E-mail: ramagundam@rm.beml.co.in

Udaipur

20-B Uchhaba Bhawan, Bedia Road,
New Fatehpura, Udaipur - 313 001.
Rajasthan

T + 91 294 2452053, 2452055
F + 91 294 2452054
E-mail: udaipur@rm.beml.co.in

Vijayawada

District Manager : Mr Rambabu

Mob +91 8330930990

Visakhapatnam

No. 8-45-11, 4h Lane, China Waltair Colony,
Visakhapatnam - 530 003

T/F 0891 2754608
E-mail: vizag@rm.beml.co.in

www.bemlindia.com

Represented by :

बी ई एम एल लिमिटेड BEML LIMITED

A Govt. of India Miniratna Company Under Ministry of Defence