

BL120H

BACKHOE LOADER

Salient Features :

- Turbo charged sturdy engine
- Equal size Tyres
- The orbital Power Steering
- Load sensing Hydraulics
- (LHS) with joystick control
- Spacious FOPS Cabin



Operating Mass	: 8,500 kg
Gross Power	: 74 kW (100hp)@2200 r/min

www.bemlindia.com

BL120H

BACKHOE LOADER

Salient Features :

ENGINE :

Beml make turbocharged diesel engine promises high performance even at high altitudes. The electronically controlled engine assures reduced fuel consumption and high operational economy.

EQUAL SIZE TYRES :

Equal size Tyres offered on BL120H increase ground contact and lower ground pressure which makes the machine capable of handling tough onsite conditions like soft ground, damp agricultural fields, construction sites with excellent stability.

CABIN :

Spacious walk through FOPS cabin, fitted with AC (optional) increases the operator comfort and safety. The adjustable seat with ergonomically placed controls reduces the operator fatigue. The modified compact instrumental panel gives all essential information.

LS HYDRAULICS WITH JOYSTICK CONTRL :

State-of-the-art load sensing Hydraulics (LSH) makes the system more fuel efficient and hence Eco-friendly. Ergonomically placed joystick controls provides maximum comfort to the operator

POWER STEERING :

The orbitrol Power steering enabled with less effort steering and steering during emergency conditions. Optimum combination of travel speed, turning radius and wheelbase increases the maneuverability.

EASY MAINTENANCE :

All filters and check points are positioned for easy access. Special dust seals are provided for all linkage joints for higher performance and less maintenance.

RELIABILITY :

All structures are made of high tensile steel for longer life. Wet multiple disc brakes on Rear axle wheels gives excellent braking & longer life for brake lining. The cutting edges, teeth pins, bushings are highly reliable and durable.



ENGINE

Make / Model	BEML BSAA4D105EG
Type	Turbo charged, 4 cylinder, water cooled, direct injection, Diesel Engine
Gross power	74 kW (100hp) @ 2200 r/min
Displacement	4.33 ℓ / 4330 cc
Maximum torque	375 Nm (38.2 kgm) @ 1400 rpm
Governor	Electronically controlled
Lubrication	Forced
Air cleaner	Dry type
Electricals	12 V, Single Battery, Alternator 12V, 90A

TRANSMISSION

Transmission	Full power shift with integral torque converter, 4 forward and 3 reverse speeds, optimally matched with engine power. Electro hydraulic controlled direction & range selector
Max. Speed	36 kmph

AXLES & FINAL DRIVE

Drive System	Four Wheel Drive
Front axle	Trunion mounted fully oscillating, drive & steerable
Rear axle	On board rigidly mounted, 100 % differential lock with electro hydraulic control

BRAKES

Service brake	Hydraulically actuated wet multiple disc brake at rear wheels
Parking Brake	Electro hydraulic actuated wet multiple disc brakes.

STANDARD EQUIPMENT

- 12 V starting motor
- 90 A Alternator
- 12 V/135 AH battery
- Portable fire extinguisher
- Front light
- Electric horn
- Rear view mirror
- All weather steel cab (with safety)
- Glass windows, lockable door, Window wiper, room lamp and adjustable seat)
- Tool kit

OPTIONAL FEATURES

- Front wheel braking system with emergency braking
- All wheel steering system
- Cold starting kit to meet High altitude and extreme cold environmental conditions
- AC cabin

OPTIONAL ATTACHMENTS

Loader

- Multi purpose bucket (6 in 1 operation)
- Fork Lift 2.2 ton
- Jib Crane 2.2ton

Backhoe

- Bucket 0.09 & 0.18 cu.m,
- Bucket 0.24 cu.m
- Bucket 0.4 cu.m(max.den 1000 kg/cu.m)
- Ditch cleaning bucket 0.18 & 0.3 cu. m
- Square hole bucket 0.1 cu. m,
- Taper ditching bucket 0.12 cu. m,
- Ripper
- Rock breaker
- Jaw Bucket
- Telescopic backhoe arm



TYRES

Front & Rear : 16.9 x 28, 12PR - 4 nos - Standard.
14.0 x 25, 20PR - 4 nos. (Optional, Heavy Duty)



STEERING

Steering mechanism Fully Hydrostatic Orbital type power steering independent of engine speed.
Relief pressure setting 175 bar (17.5 Mpa)



HYDRAULICS

Pump type & capacity Variable Piston pump, 125ℓpm @ 2200 rpm
Relief pressure 210 bar (21 Mpa)
Loader & Backhoe



FILTER SYSTEM

Engine Two stage fuel filter with water separator
Air intake Dry type, two stage air cleaner with dust evacuator
Hydraulic Return line filter



MASS (kg)

Operating Mass 8500 kg (including work attachments, coolant, fuel tank and operator)



REFILL CAPACITY (ltrs)

Hydraulic	110	Engine oil	11.5
Fuel tank	145	Transmission	15
Engine coolant	14	Rear Axle	18
Front axle	18		



CABIN CONTROL PANEL

Cabin FOPS roomy cabin with excellent visibility, fitted with 2 doors & 2 side windows and sliding rear window.
Control Panel Ergonomically located controls and dashboard for loader and backhoe operation



BUCKET CAPACITY

Loader	1.2 cu.m
Backhoe	0.3 cu.m



TURNING CIRCLE

A	Outside loader bucket	18.9 m
B	Outside wheels	17.24 m



LOADER PERFORMANCE

Bucket capacity (SAE rated)	1.2 cu.m
Max. Dumping clearance	2800 mm (Cutting Edge)
Operating height (fully raised)	4522 mm
Max. Digging depth	282 mm
Bucket dumping angle	45 Deg.
Bucket Breakout force	61 kN
Arm Breakout force	48.9 kN



BACKHOE PERFORMANCE

Max. Dumping Clearance	4120 mm
Operating Height (fully raised)	5984 mm
Max. Digging Depth	4731 mm
Bucket Capacity	0.3 cu.m
Bucket rotation	180 Degrees
Total side shift travel	900 mm
Bucket dig force	60.8 kN
Arm crowding force	36 kN

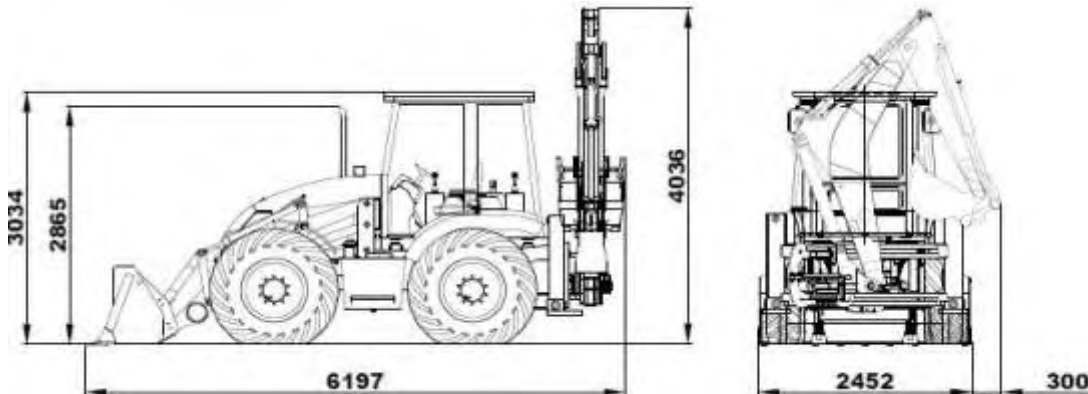
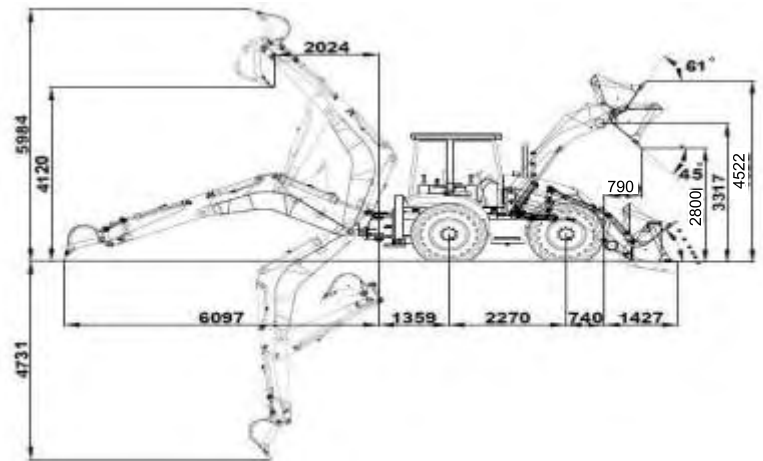

Specifications are subject to change without notice, Illustrations may include optional equipment & accessories

बी ई एम एल लिमिटेड

BEML LIMITED

A Govt. of India Miniratna Company Under Ministry of Defence

Business Network	Corporate Office	International Business Division	Marketing Division	Global Service HQ
	BEML Soudha, 23/1, 4th Main, S.R. Nagar, Bangalore-560 027	BEML Soudha, 23/1, 4th Main, S.R. Nagar, Bangalore-560 027	5th Floor, Unity Building, J.C. Road, Bangalore-560 002	C-6, Central Hingna Road, MIDC Industrial Area, Hingna, Nagpur-440 028
	T + 91 80 22963240, 22963250 F + 91 80 22963278/516/280/164	T + 91 80 22222730, 22233350 22963187, 22963215 F + 91 80 22224874	T + 91 80 22963501/02/07/510/553 F + 91 80 22963541	T + 91 7104 287097/287098 F + 91 7104 287099
	E-mail: office@cpd.beml.co.in office@pr.beml.co.in	E-mail: office@export.beml.co.in	E-mail: m@beml.co.in bemldealer@dealer.beml.co.in	E-mail: ss.servicehq@gmail.com ss@servicehq.beml.co.in

REGIONAL OFFICES

Bangalore No -23/1, Haudin Road Cross, Ulsoor Road, Bangalore - 560008 Karnataka	T + 91 080 22963590/92/93/94 F + 91 080 2558156 E-mail: mg@beml.co.in
Bilaspur 1/A, Sector-C, Sirgitti Industrial Area, P.O: Tifra, Bilaspur - 495 223. Chattisgarh.	T + 91 7752 252745, 252598 F + 91 7752 252065 E-mail: bilaspur@rm.beml.co.in
Chennai Flat No. 10&11, Supriya Estates, Sterling Road, Nungambakkam, Chennai - 600 034, Tamil Nadu	T + 91 44 28276576 / 228220844 F + 91 44 28257319 E-mail: chennai@rm.beml.co.in
Dhanbad Kamal Kunj, Kola Kusuma, Saraidhela, Dhanbad - 828 127 Jharkhand	T + 91 326 2200180 / 2208982/5827 F + 91 326 2200182 E-mail: dhanbad@rm.beml.co.in
Hyderabad 3-6-114, Himayat Nagar, Hyderabad - 500 029 Andhra Pradesh	T + 91 40 23225250 / 7032 / 2166 F + 91 40 23221794 E-mail: hyderabad@rm.beml.co.in
Kolkata 35/1, Taratala Road, Kolkata - 700 088. West Bengal	T + 91 33 24015286 / 87 / 98 / 99 F + 91 33 24015288 E-mail: kolkata@rm.beml.co.in
Mumbai C/o Richardson & Cruddas (1972) Ltd. 3rd Floor, Corporate Office Building Sir J.J Road Byculla, Mumbai - 400 020	T + 91 22 23781457 / 23781382 F + 91 22 23780915 E-mail: mumbai@rm.beml.co.in
Nagpur 33, Cement Road, Shivaji Nagar, Nagpur - 440 010, Maharashtra.	T + 91 0712 2248435 / 2248343 F + 91 0712 2249997 E-mail: nagpur@rm.beml.co.in
New Delhi Flat EFGH, 'Vandana', 11th Floor, Tolstoy Marg, New Delhi - 110 001	T + 91 11 23310035 / 23316500 F + 91 11 23325085 E-mail: delhi@rm.beml.co.in
Ranchi 206/D-1, Bhagirathi, (Behind NCC Campus), Rameshwaram Colony, Bariatu Road, Ranchi, Jharkhand - 834009	T + 91 651 2540710 / 2540791 F + 91 651 2540624 E-mail: ranchi@rm.beml.co.in
Sambalpur BEML Complex, NH-6, Baraipalli, Sambalpur - 768 150 Orissa.	T + 91 663 2521604 / 2520393 F + 91 663 2521603 E-mail: sambalpur@rm.beml.co.in
Singrauli PB No. 5, Jhingurdha Colliery, Sidhi, Singrauli - 486 889 Madhya Pradesh.	T + 91 7805 268260 / 266668 F + 91 7805 267282 / 318 E-mail: singrauli@rm.beml.co.in

DISTRICT OFFICES

Ahmedabad 266-1, Dilbaug Villa, Darshan Society Road, Navrangpura, Ahmedabad - 380 009. Gujarat	T + 91 79 26445523 F + 91 79 26423950 E-mail: ahmedabad@rm.beml.co.in
Asansol 3, Bumpur Road, Asansol - 713 304 West Bengal	T + 91 341 2252480 F + 91 341 2250601 E-mail: asansol@rm.beml.co.in
Bacheli Behind Central Stores of NMDC Ltd., Depot 5, Bacheli - 494 553. Chhattisgarh	T + 91 7857 200518 F + 91 7857 230005 E-mail: bacheli@rm.beml.co.in
Bhopal Ground Floor, Hall No.1, Chittod Complex Zone-1, Maharana Pratap Nagar (MP Nagar) Bhopal - 462 023	T + 91 755 2550711 E-mail: bemlbhopal@gmail.com

DISTRICT OFFICES

Bhubaneswar 252/A, LEWIS Road, Bhubaneswar - 751 014 Orissa	T + 91 674 2434428 T/F + 91 674 2434427 E-mail: bhuvaneshwar@rm.beml.co.in
Chandrapur Mamidwar, Tiles Factory Compound, Ghugus Road, Padoli, Chandrapur - 442 406 Maharashtra	T + 91 7172 287230 F + 91 7172 287072 E-mail: chandrapur@rm.beml.co.in
Cochin No. 55/845, Chittor Road, Ernakulam South Cochin-682 016	T + 91 484 2375138 E-mail: bemlkochi@gmail.com
GOA 67-12, Dattaprasad Building, 3rd Floor, MG road Timphoni School, Panjim, - 403001, Goa	T + 91 832 2225135 E-mail: goa@rm.beml.co.in
Guwahati Hegrabari Road, House No. 11, Ganesh Puri, Dispur, Guwahati - 781 006 Assam	T + 91 361 2232966 F + 91 361 2232967 E-mail: guwahati@rm.beml.co.in
Hospet No. 1431, Manjunatha Complex, New Ward No. 31, Bhagat Singh Nagar, Opp. KSSIDC Indl. Estate, Dam Road, Hospet - 583 203, Karnataka	T + 91 8394 230173 F + 91 8394 230172 E-mail: hospet@rm.beml.co.in
Jammu 62C, Block D/C, Gandhi Nagar, Jammu tawi - 180 004 Jammu and Kashmir	T + 91 191 2430447 F + 91 191 2477469 E-mail: jammu@rm.beml.co.in
Kothagudem Old Project Planning Department, Near SCCL Corporate Office, Kothagudem - 507 101, Andhra Pradesh	T + 91 8744 245572 F + 91 8744 245530 E-mail: kothagudem@rm.beml.co.in
LEH #135, Fort Road, Sheynam LEH, Ladakh, 194 101	T + 91 9622973460 E-mail: bemlleh@gmail.com
Madurai 9-4/49, Kalai Nagar, IInd Main Road, Madurai - 625 017, Tamil Nadu.	T/F + 91 452 2649458 E-mail: madurai@rm.beml.co.in
Neyveli F-4, Rajendraprasad Road, Block-27 Neyveli - 607 803, Tamil Nadu	T/F + 91 4142 268517 E-mail: neyveli@rm.beml.co.in
Panjim 67-12, Dattaprasad Building, III Floor, MG Road, Timphoni School, Panjim - 403 001. Goa	T/F 91 832 2225135 E-mail: goa@rm.beml.co.in
Ramagundam Opp. SCCL 11A Mines, Manthani, (PO) Jallaram, GK - 505 184 Karimnagar Dt. Andhra Pradesh	T + 91 8728 248299 F + 91 8728 247423 E-mail: ramagundam@rm.beml.co.in
Udaipur 20-B, Uchhab Bhawan, Bedia Road, New Fatehpura, Udaipur - 313 001. Rajasthan	T + 91 294 2452053, 2452055 F + 91 294 2452054 E-mail: udaipur@rm.beml.co.in
Vijayawada District Manager : Mr Rambabu	Mob +91 8330930990
Visakhapatnam No. 8-45-11, 4h Lane, China Waltair Colony, Visakhapatnam - 530 003	T/F 0891 2754608 E-mail: vizag@rm.beml.co.in

www.bemlindia.com

Represented by :

Form No. BL120H/001/2015

बी ई एम एल लिमिटेड

BEML LIMITED

A Govt. of India Miniratna Company Under Ministry of Defence

Tyre Handler From BEML :

BL9H

BL9H (4x4)

B19

BL120H

BL200-1